



Ditec NeoS / NeoS+ Sliding Gates

(Translation of the original instructions)

IP2160EN • 2019-01-30
Technical Manual

Contents

Subject		Page
1.	General safety precautions	3
	General safety precautions for the user	4
2.	Declaration of incorporation of partly completed machinery	5
2.1	Machinery Directive	5
3.	Technical specifications	6
3.1	Operating instructions	7
4.	Standard installation	8
5.	Dimensions	9
6.	Main components	9
7.	Installation	10
7.1	Preliminary checks	10
7.2	Base plate position	11
7.3	Gearmotor installation	12
7.4	Rack installation	13
7.5	Operation with encoder	14
7.6	Magnetic limit switch installation and adjustment	14
7.7	Chain drive kit installation	15
8.	Electrical connections	17
8.1	Installation of internal photocell	18
9.	Routine maintenance plan	18
	Operating instructions	19

Key



This symbol indicates instructions or notes regarding safety, to which special attention must be paid.



This symbol indicates useful information for the correct functioning of the product.

All the rights concerning this material are the exclusive property of Entrematic Group AB.

Although the contents of this publication have been drawn up with the greatest care, Entrematic Group AB cannot be held responsible in any way for any damage caused by mistakes or omissions in this publication. We reserve the right to make changes without prior notice.

Copying, scanning and changing in any way are expressly forbidden unless authorised in writing by Entrematic Group AB.

1. General safety precautions



Failure to respect the information given in this manual may cause personal injury or damage to the device.

Keep these instructions for future reference

This installation manual is intended for qualified personnel only.

Installation, electrical connections and adjustments must be performed by qualified personnel, in accordance with Good Working Methods and in compliance with the current regulations. Read the instructions carefully before installing the product.

Bad installation could be dangerous.



The packaging materials (plastic, polystyrene, etc.) should not be discarded in the environment or left within reach of children, as they are a potential source of danger.

Before installing the product, make sure it is in perfect condition.

Do not install the product in explosive areas and atmospheres: the presence of inflammable gas or fumes represents a serious safety hazard.

Before installing the motorisation device, make all the necessary structural modifications to create safety clearance and to guard or isolate all the crushing, shearing, trapping and general hazardous areas.

Make sure the existing structure is up to standard in terms of strength and stability. The motorisation device manufacturer is not responsible for failure to observe Good Working Methods when building the frames to be motorised, or for any deformation during use.

The safety devices (photocells, safety edges, emergency stops, etc.) must be installed taking into account: applicable laws and directives, Good Working Methods, installation premises, system operating logic and the forces developed by the motorised door or gate.

The safety devices must protect against crushing, cutting, trapping and general danger areas of the motorised door or gate.

Display the signs required by law to identify hazardous areas.

Each installation must bear a visible indication of the data identifying the motorised door or gate.

When necessary, connect the motorised door or gate to an effective earthing system that complies with the current safety standards.



During installation, maintenance and repair operations, cut off the power supply before opening the cover to access the electrical parts.

The automation protection casing must be removed by qualified personnel only.

The electronic parts must be handled using earthed antistatic conductive arms. The manufacturer of the motorisation declines all responsibility if component parts not compatible



with safe and correct operation are fitted.

Only use original spare parts for repairing or replacing products.

The installer must supply all information concerning the automatic, manual and emergency operation of the motorised door or gate, and must provide the user with the operating instructions.

General safety precautions for the user



These precautions are an integral and essential part of the product and must be supplied to the user.

Read them carefully since they contain important information on safe installation, use and maintenance.

These instructions must be kept and forwarded to all possible future users of the system.

This product must only be used for the specific purpose for which it was designed.

Any other use is to be considered improper and therefore dangerous. The manufacturer cannot be held responsible for any damage caused by improper, incorrect or unreasonable use.

Avoid operating in the proximity of the hinges or moving mechanical parts. Do not enter within the operating range of the motorised door or gate while it is moving.

Do not obstruct the motion of the motorised door or gate, as this may cause a dangerous situation.

The motorised door or gate may be used by children over the age of 8 and by people with reduced physical, sensorial or mental abilities, or lack of experience or knowledge, as long as they are properly supervised or have been instructed in the safe use of the device and the relative hazards.

Children must be supervised to make sure they do not play with the device, nor play/remain in the sphere of action of the motorised door or gate.

Keep remote controls and/or any other command devices out of the reach of children, to avoid any accidental activation of the motorised door or gate.

In the event of a product fault or malfunction, turn off the power supply switch. Do not attempt to repair or intervene directly, and contact only qualified personnel.

Failure to comply with the above may cause a dangerous situation.

Any repair or technical intervention must be carried out by qualified personnel.



Cleaning and maintenance work must not be carried out by children unless they are supervised.

To ensure that the system works efficiently and correctly, the manufacturer's indications must be complied with and only qualified personnel must perform routine maintenance on the motorised door or gate. In particular, regular checks are recommended in order to verify that the safety devices are operating correctly.

All installation, maintenance and repair work must be documented and

made available to the user.

Only lock and release the door wings when the motor is switched off.
Do not enter within the operating range of the wing.

 To dispose of electrical and electronic equipment correctly, users  must take the product to special "recycling centres" provided by the municipal authorities.

2. Declaration of incorporation of partly completed machinery

(Directive 2006/42/EC, Annex II-B)

The manufacturer Entrematic Group AB, with headquarters in Lodjursgatan 10, SE-261 44 Landskrona, Sweden, declares that the automation for Ditec sliding gates NES400EH, NES400EHP, NES400EHJ, NES600EH, NES600EHP, NES600EHSF, NES600EHJ, NES600ESFHJ, NES1000EHP, NES1000EHPJ:

- is designed to be installed on a manual gate to form a machine pursuant to Directive 2006/42/EC. The manufacturer of the motorised gate must declare conformity with Directive 2006/42/EC (annex II-A) prior to initial machine start-up;
- complies with the applicable essential safety requirements indicated in Annex I, Chapter 1 of the Directive 2006/42/EC;
- complies with the Electromagnetic Compatibility Directive 2014/30/EU;
- complies with the RED Directive 2014/53/EU;
- the safety functions are compliant with Category 2, PLc according to EN ISO 13849-1;
- the technical documentation complies with Annex VII-B of the Directive 2006/42/EC;
- the technical documentation is managed by the Technical Office of Entrematic Italy (with headquarters in Largo U. Boccioni 1 – 21040 Origgio (VA) – ITALY) and is available upon request, sending an e-mail to ditec@entrematic.com ;
- a copy of the technical documentation will be given to competent national authorities, following a suitably justified request.

Landskrona, 21-08-2018

Matteo Fino
(Chairman)

2.1 Machinery Directive









Pursuant to Machinery Directive (2006/42/EC) the installer who motorises a door or gate has the same obligations as the manufacturer of machinery and as such must:

- prepare the technical data sheet which must contain the documents indicated in Annex V of the Machinery Directive;
(The technical data sheet must be kept and placed at the disposal of competent national authorities for at least ten years from the date of manufacture of the motorised door);
- draw up the EC Declaration of Conformity in accordance with Annex II-A of the Machinery Directive and deliver it to the customer;
- affix the EC marking on the motorised door or gate, in accordance with point 1.7.3 of Annex I of the Machinery Directive;
- ensure compliance of the motorised door or gate with safety regulations, by installing the necessary safety devices;
- carry out the safety test **S4**, modifying parameters **D6** and **D8** (if used) from the **AP** menu;
- refer to the installation manual of the CS12E - CS12M control panel for the operating force adjustments, in compliance with EN12453 and EN12445.

3. Technical specifications

	Ditec NES400EH	Ditec NES400EHP	Ditec NES400EHJ
Power supply	230 V~ 50/60Hz	230 V~ 50/60Hz	120 V~ 50/60Hz
Absorption	1,2 A	1,2 A	2,4 A
Fuse	F2A	F2A	F4A
Thrust	400 N	400 N	400 N
Wing speed	0,1±0,25 m/s	0,1±0,25 m/s	0,1±0,25 m/s
Max stroke	12 m	12 m	12 m
Max wing weight	400 kg	400 kg	400 kg
Service class	4 - INTENSE	4 - INTENSE	4 - INTENSE
Intermittence	S2 = 30 min - S3 = 50%	S2 = 30 min - S3 = 50%	S2 = 30 min - S3 = 50%
Operating temperature	-20° C +55° C	-20° C +55° C	-20° C +55° C
	-35° C +55° C with active NIO	-35° C +55° C with active NIO	-35° C +55° C with active NIO
Degree of protection	IP24	IP24	IP24
Control panel	CS12E	CS12M	CS12E

	Ditec NES600EH	Ditec NES600EHP	Ditec NES600EHSF	Ditec NES600EHJ	Ditec NES600EHSFJ
Power supply	230 V~ 50/60Hz	230 V~ 50/60Hz	230 V~ 50/60Hz	120 V~ 50/60Hz	120 V~ 50/60Hz
Absorption	1,5 A	1,5 A	1,5 A	3 A	3 A
Fuse	F2A	F2A	F2A	F4A	F4A
Thrust	600 N	600 N	300 N nominal 500 N start-up	600 N	300 N nominal 500 N start-up
Wing speed	0,1±0,24 m/s	0,1±0,24 m/s	0,1±0,4 m/s	0,1±0,24 m/s	0,1±0,4 m/s
Max stroke	20 m	20 m	20 m	20 m	20 m
Max wing weight	600 kg	600 kg	600 kg	600 kg	600 kg
Service class	4 - INTENSE	4 - INTENSE	4 - INTENSE	4 - INTENSE	4 - INTENSE
Intermittence	S2 = 30 min S3 = 50%	S2 = 30 min S3 = 50%	S2 = 30 min S3 = 50%	S2 = 30 min S3 = 50%	S2 = 30 min S3 = 50%
Operating temperature	-20° C +55° C	-20° C +55° C	-20° C +55° C	-20° C +55° C	-20° C +55° C
	-35° C +55° C with active NIO	-35° C +55° C with active NIO	-35° C +55° C with active NIO	-35° C +55° C with active NIO	-35° C +55° C with active NIO
Degree of protection	IP24	IP24	IP24	IP24	IP24
Control panel	CS12E	CS12M	CS12E	CS12E	CS12E

	Ditec NES1000EHP	Ditec NES1000EHPJ
Power supply	230 V- 50/60Hz	120 V- 50/60Hz
Absorption	2 A	4 A
Fuse	F2,5 A	F6,3A
Thrust	1000 N	1000 N
Wing speed	0,1±0,19 m/s	0,1±0,19 m/s
Max stroke	20 m	20 m
Max wing weight	1000 kg	1000 kg
Service class	4 - INTENSE	4 - INTENSE
Intermittence	S2 = 30 min S3 = 50%	S2 = 30 min S3 = 50%
Operating temperature	 -20° C  +55° C	 -20° C  +55° C
	 -35° C  +55° C with active NIO	 -35° C  +55° C with active NIO
Degree of protection	IP24	IP24
Control panel	CS12M	CS12M

3.1 Operating instructions

Service class: 4 (minimum 10-5 years of working life with 100-200 cycles per day).

Applications: INTENSE (for apartment block, industrial and commercial entrances and car parks with vehicle access or access for intense pedestrian use).

- Performance characteristics are to be understood as referring to the recommended weight (approx. 2/3 of maximum permissible weight). When used with the maximum permissible weight a reduction in the above mentioned performance can be expected.
- Service class, running times, and the number of consecutive cycles are to be taken as merely indicative, having been statistically determined under average operating conditions, and are therefore not necessarily applicable to specific conditions of use.
- Each automatic entrance has variable elements such as: friction, balancing and environmental factors, all of which may substantially alter the performance characteristics of the automatic entrance or curtail its working life or parts thereof (including the automatic devices themselves). The installer should adopt suitable safety conditions for each particular installation.

4. Standard installation

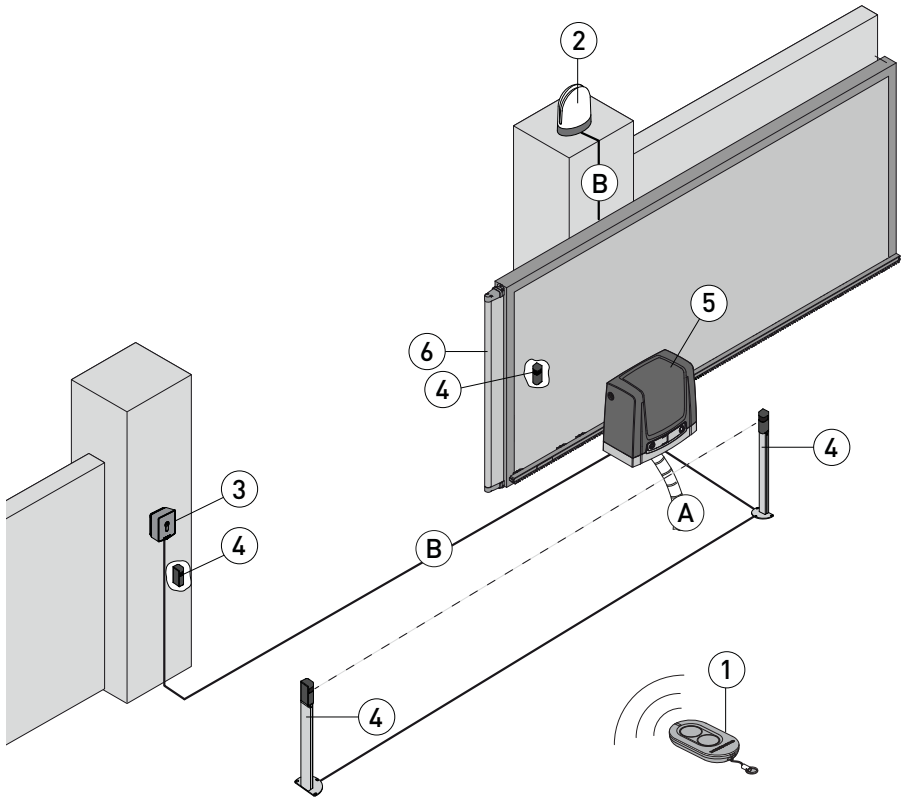

Rif.	Description	Cable
1	Remote control	/
2	Flashing light Antenna (integrated into the flashing light)	2 x 1 mm ² coaxial 58 Ω
3	Key selector switch Digital combination wireless keypad	4 x 0,5mm ² /
4	Photocells	4 x 0,5 mm ²
5	Actuator NEOS with control panel	3G x 1,5 mm ²
6	Safety edge	2 x 0,5 mm ²
A	Connect the power supply to a type-approved omnipolar switch, with a contact opening distance of at least 3mm (not supplied). The connection to the mains must follow an independent path, separate from the connections to the control and safety devices.	

5. Dimensions

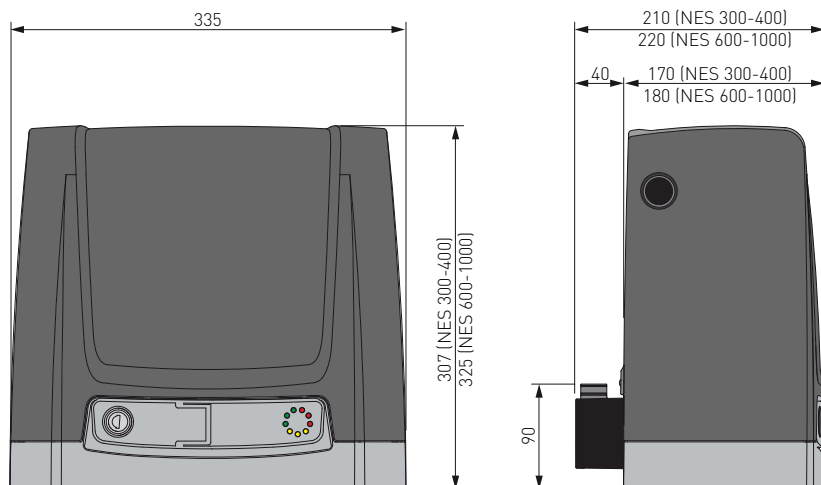

6. Main components

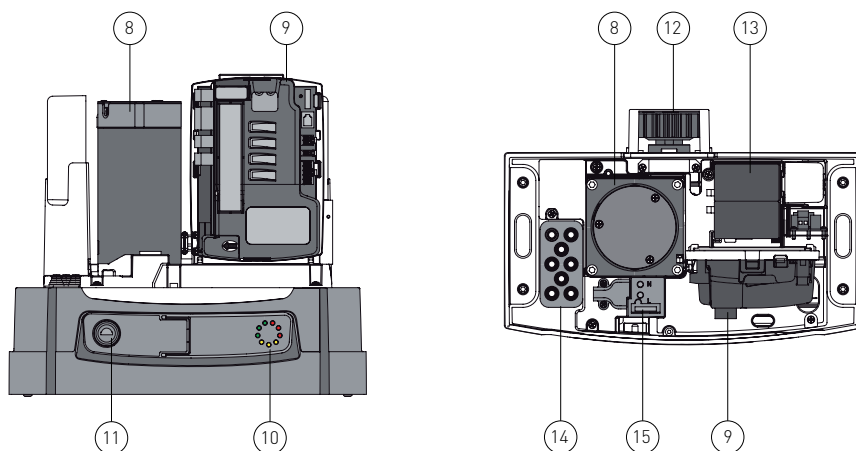

Ref.	Code	Description
8		Motor
9		Control panel
10		Diagnostic circuit
11		Key release
12		Pinion
13		Battery kit
14		Cable inlet
15		Power supply terminal

7. Installation

The given operating and performance features can only be guaranteed with the use of DITEC accessories and safety devices.

Unless otherwise specified, all measurements are expressed in mm.

7.1 Preliminary checks

Check the stability of the wing (derailing and lateral falls) and the sliding wheels and that the upper guides do not cause any friction.

The sliding guide must be securely fixed to the ground for the full length within doorway and must have no irregularities that could hinder the movement of the wing.

The opening and closing stops must be fitted.

If the gate has slits, make sure they are covered to prevent shearing points or install active safety edges on the columns.

Safety device should be installed at the end of the wing to reduce the collision force.



NB: make sure that the gate can not exit the sliding guides and fall.

7.2 Base plate position

- [1] Insert the anchor ties into the base plate and fix them with the supplied nuts.
 - [2] Insert the screws in the base plate, secure them with the nuts and then bend the metal tab to prevent the screw from coming out.
 - Extract the preformed ties with a downwards movement using a hammer to ensure correct anchorage to the concrete.
- Make a concrete base with the anchor ties and base plate embedded, which must be level and clean and of the size indicated in the figure.



NB: if the concrete base has already been made, base plate [2] can be fixed using M8 plugs (not supplied).

1

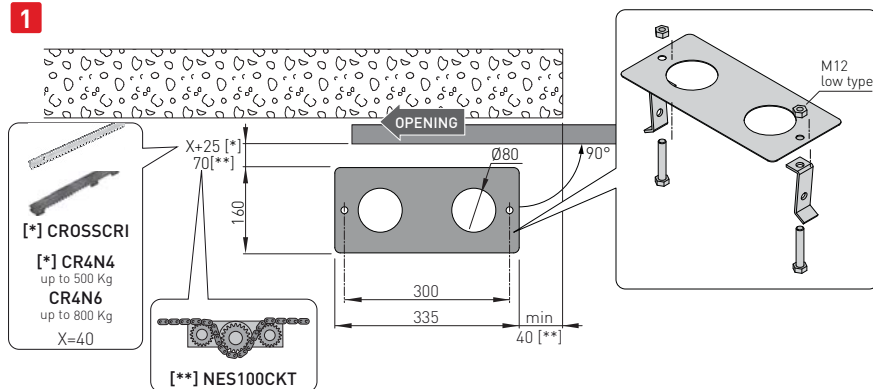

2

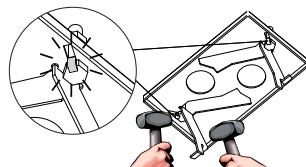
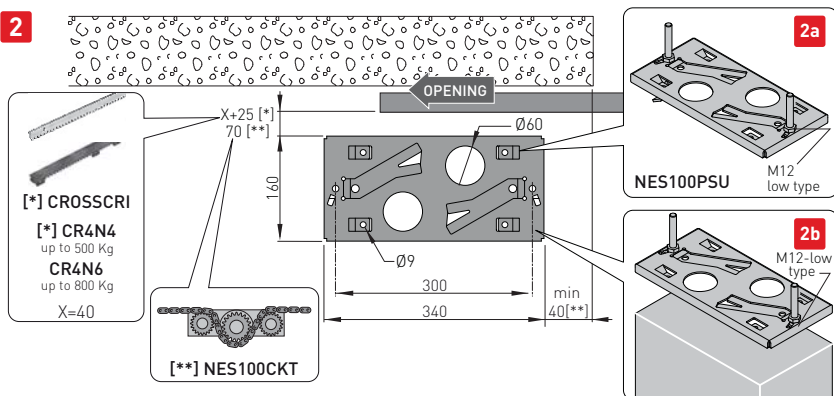

7.3 Gearmotor installation

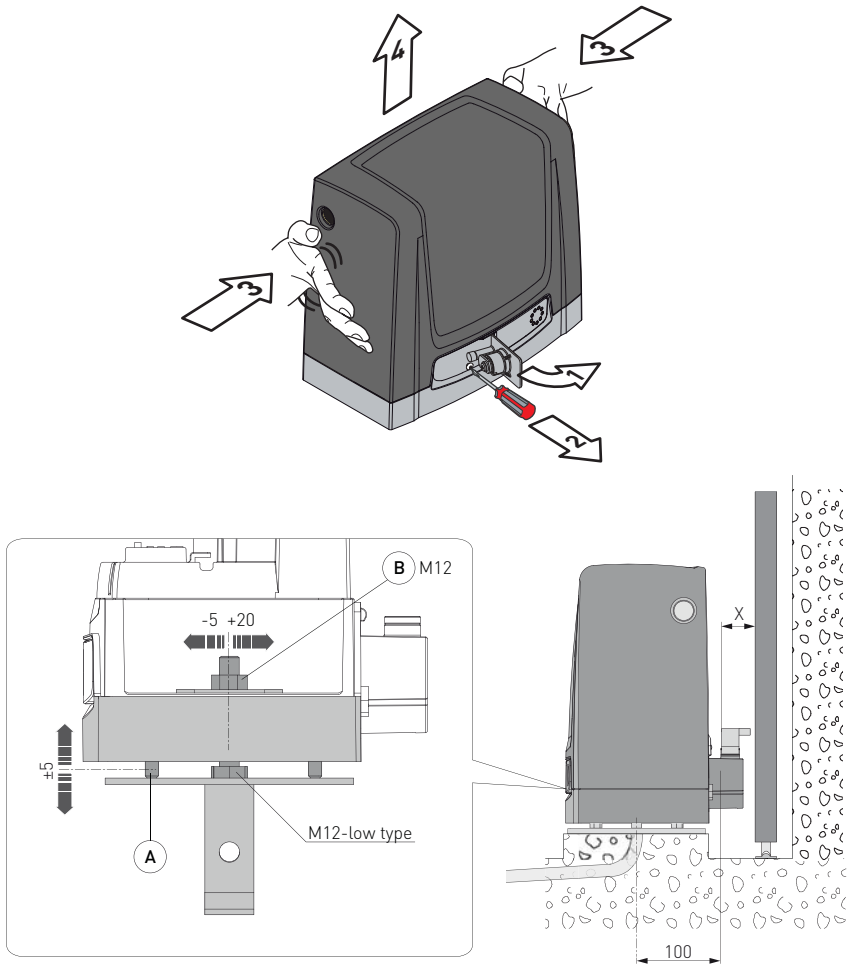

- Release the gearmotor [1] (see OPERATING INSTRUCTIONS). Loosen the front screw [2] and remove the casing by pressing on its sides [3-4].
- Place the gearmotor on the base plate.
- Adjust the gearmotor horizontally by sliding it along the slots of the gearmotor base and vertically with four levelling screws [A].
NB: during the vertical adjustment, keep the gearmotor slightly raised from the base plate so that the rack can be fixed and subsequent adjustments are possible.
- After adjusting, fix the gearmotor using screws [B].



WARNING: The gearmotor must be suitably raised from the ground to avoid flooding.

7.4 Rack installation

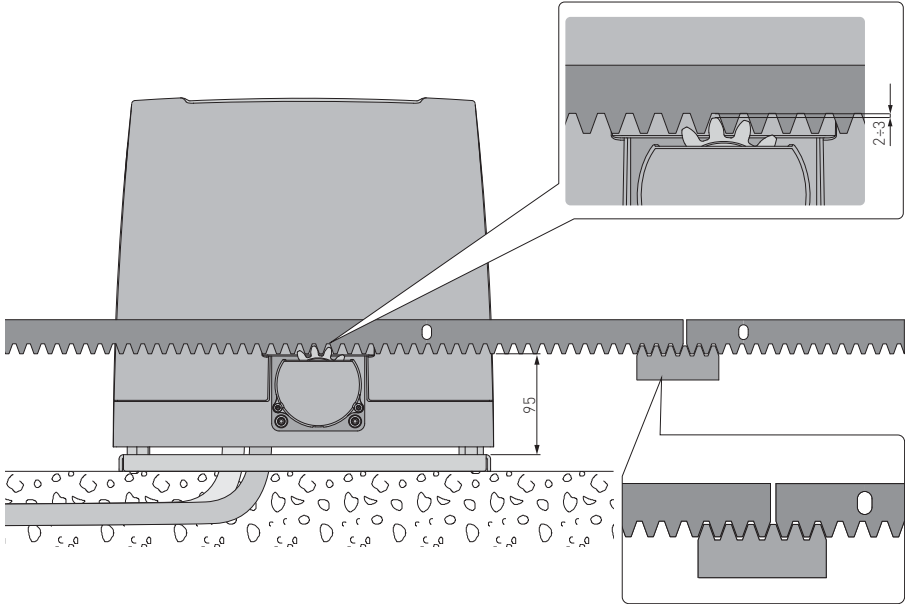

- Release the gearmotor (see OPERATING INSTRUCTIONS) and open the gate.
 - Place the rack against the pinion and sliding the gate manually fix it along its whole length.
- NB: To make it easier to align the rods correctly, use a scrap piece of rack and rest it underneath the junction point, as shown in the figure detail.
- Once fixed, vertically adjust the gearmotor to give a play of about 2 to 3 mm between the pinion and the rack.
 - Secure the gearmotor.
 - Slightly lubricate the rack and pinion after assembly.
- Manually check that the gate slides evenly and without friction.

7.5 Operation with virtual encoder

NEOS gearmotors do not require limit switches because they have a virtual encoder. Mechanical opening and closing end stops must be installed.

The gate automatically slows when approaching the end stops.

WARNING: when the gate reaches the opening or closing limit stop, it reverses briefly to facilitate manual release of the gearmotor.

7.6 Magnetic limit switch installation and adjustment

For the installation of the limit switch kit, refer to the Nes100FCM manual.

- Manually place the wing in the open position and fix limit switch brackets [A] and [B] on rack [C]. Repeat this operation with the wing in the closed position.
- After a few manoeuvres, adjust the position of limit switch brackets [A] and [B] so that the gate stops about 20 mm before reaching the opening and closing mechanical stops.



The limit switch kit is optional and is used to stop the gate before it reaches the opening and closing mechanical stops.

With a limit switch installed, slowdown is carried out at regulated power to overcome possible friction.

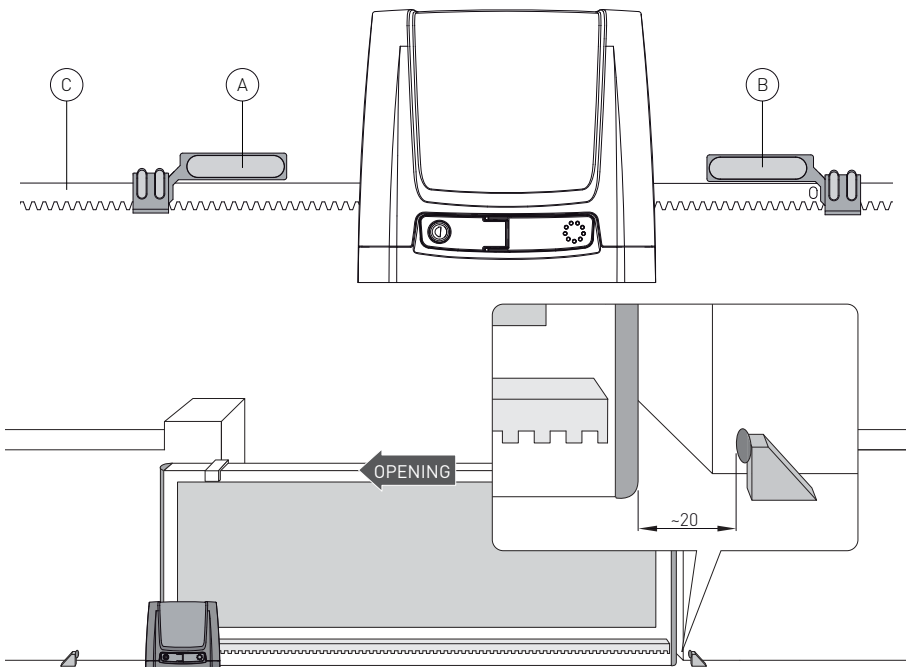

7.7 Chain drive kit installation

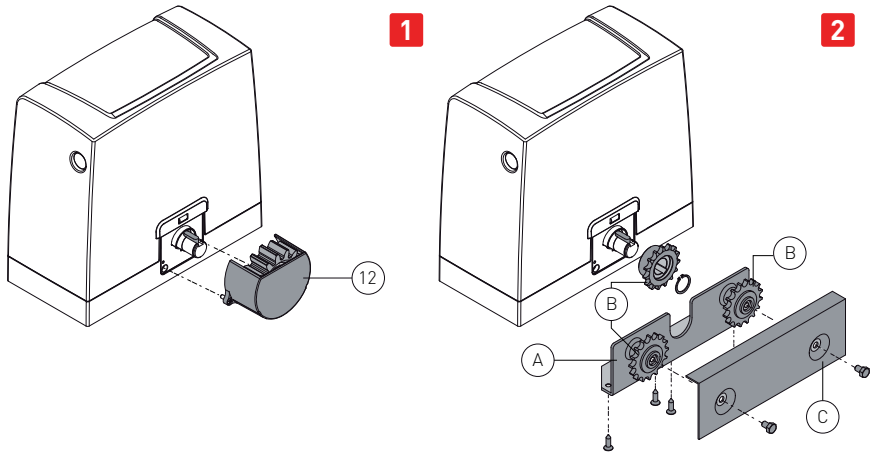

NB: Install the chain drive kit before securing the gearmotor to the base plate.

- Release the gearmotor (see OPERATING INSTRUCTIONS).
- [1] Remove pinion [12].
- [2] Fix pinion supporting plate [A] to the gearmotor.
- Insert pinions [B] as illustrated in the diagram.
- [3] Pass the chain between the pinions by hand.
- Fix cover plate [C].

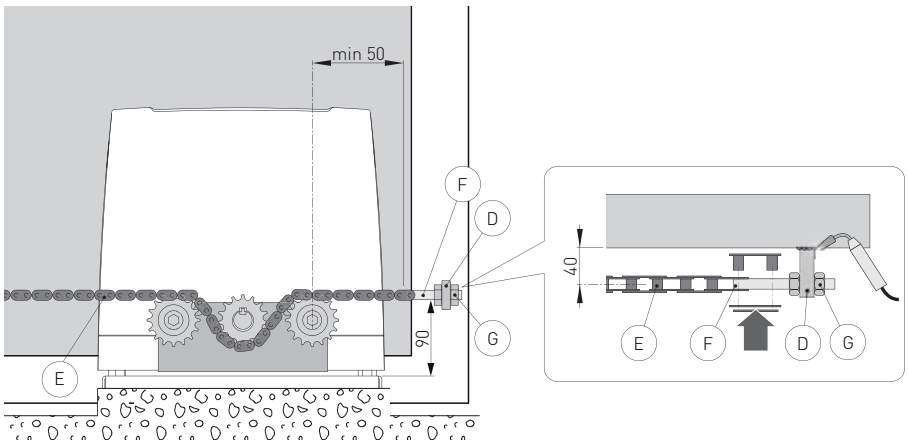

- Move the wing into the open position by hand and fix brackets [D] on the wing as illustrated in the diagram.
- Connect chain [E], which was previously assembled on the gearmotor, to tie rod [F] and fix it to bracket [D].
- Fix bracket [D] on the opposite side of the gate. Connect chain [E] to tie rod [F] and fix it to bracket [D] (cut the excess chain).

NB: Make sure that the distance between the pinion centre and tie rod [F] is correct when the gate is fully open and closed.

- Secure the chain with nuts [G].
- Tighten the chain [E] with the tie rods [F].
- Slightly lubricate the chain [E] and the pinions after assembly.



WARNING: when the chain traction kit is fitted, the gearmotor drive direction is inverted.

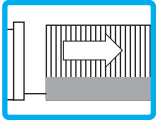

LF Right-hand opening

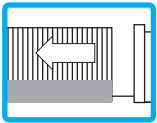

RT Left-hand opening

8. Electrical connections



NB: the electrical wiring and start-up of the gearmotors is shown in the CS12E and CS12M control panel installation manuals.

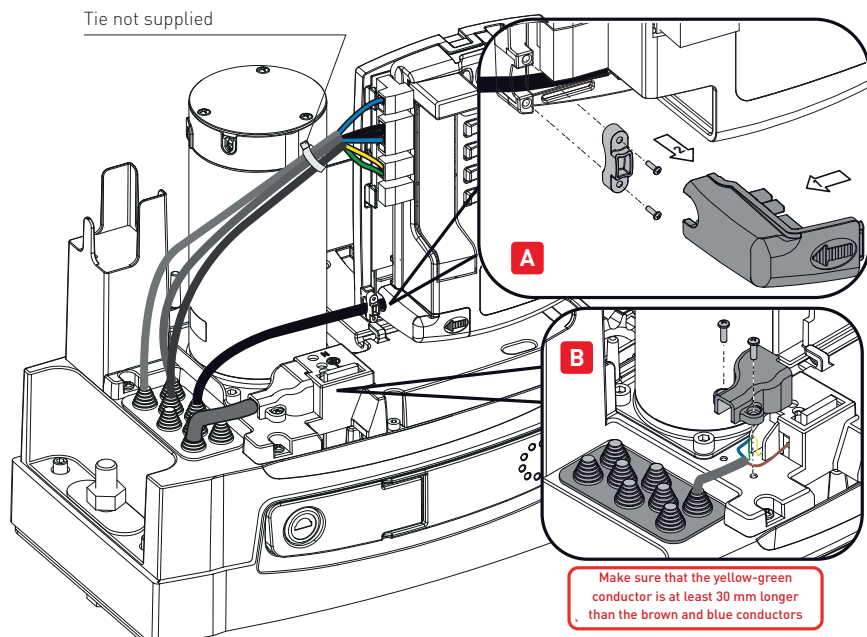

Before connecting the power supply, make sure the plate data correspond to that of the mains power supply.

An omnipolar disconnection switch with a contact opening distance of at least 3mm must be fitted on the mains supply.

Check there is an adequate residual current circuit breaker and overcurrent cutout upstream of the electrical system.

For the power supply, use a H05RN-F 3G1.5 type electric cable. Connect it to terminals L (brown), N (blue), \perp (yellow/green) inside the automation.

NOTE: the maximum permissible section of the wire is AWG14 (2 mm²).

Unsheathe the power supply cable in line with the terminal, and use a cable fastener to hold it in place (see ref. B).

In order to comply with essential requirements of standards in force, reclose the cover once the wires have been connected to the terminal.

In the external automation section, the connections to the mains power supply and any other low voltage wires (230V) must be made on an independent channel separated from the connections to the command and safety devices (SELV = Safety Extra Low Voltage).

The channel must penetrate the automation through the holes on the base plate by a few centimetres.

Make sure there are no sharp edges that may damage the power supply cable.

Make sure the mains power wires (230V) and the accessory wires (24V) are separated. The cables must be double insulated. Unsheathe them in line with the relative connection terminals, and use cable fasteners (see ref. A) or straps (not supplied by us) to hold them in place.

8.1 Installation of internal photocell

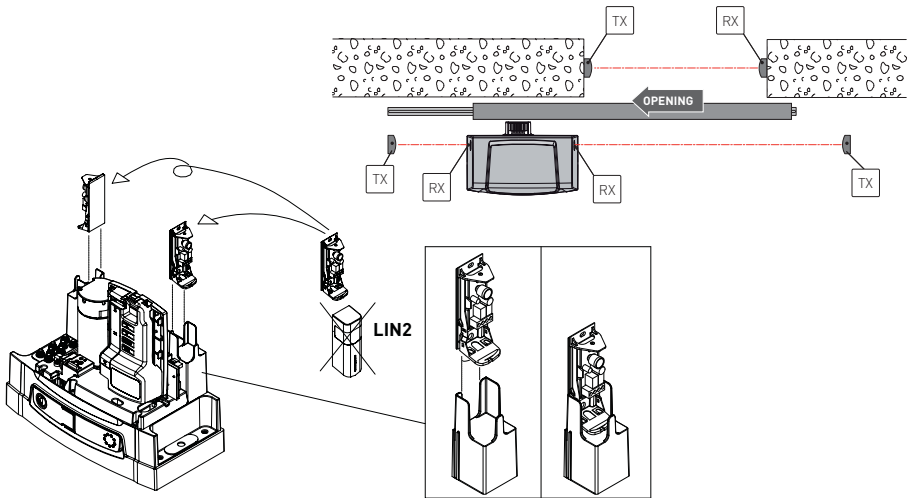

Additional photocells can be installed inside the gearmotor casing of Ditec NEOS, to protect both opening and closing movements by using the LIN2 photocell.

Fit a receiver (RX) or a transmitter (TX) as shown in the figure.

Installation of the photocells must comply with standards EN12453 and EN12445.

WARNING: the photocell receiver (RX) and transmitter (TX) may also be installed at two different heights, the maximum permissible difference in height being 300 mm.

Electrical connections

Connect the N.C. contact to the safety or stop contacts of the control panel.



For further informations, refer to the photocell installation manual.

9. Routine maintenance plan

Perform the following operations and checks every 6 months, according to the intensity of use of the automation.

Disconnect the 230 V~ power supply and batteries (if fitted) and release the gearmotor:

- Visually check that the gate, the fixing brackets and existing structure have suitable mechanical strength and are in good condition.
- Check the gate-gearmotor alignment, the distance (2-3 mm) between the groove of the pinion and the crest of the rack.
- Clean the wheel's sliding guide, the rack and pinion of the gearmotor and slightly lubricate the rack and pinion. Manually check that the gate slides evenly and without friction.

Connect the 230 V~ power supply and batteries (if fitted) and lock the gearmotor:

- Make sure the limit switches are working correctly.
- Check the power adjustment.
- Check that all control and safety functions are working correctly.



NB: For spare parts, see the spares price list.

All the rights concerning this material are the exclusive property of Entrematic Group AB. Although the contents of this publication have been drawn up with the greatest care, Entrematic Group AB cannot be held responsible in any way for any damage caused by mistakes or omissions in this publication. We reserve the right to make changes without prior notice. Copying, scanning and changing in any way are expressly forbidden unless authorised in writing by Entrematic Group AB.

ENTRE//MATIC



Entrematic Group AB
Lodjursgatan 10
SE-261 44, Landskrona
Sweden
www.entrematic.com

